

## Features

- **N-Channel MOSFET**
- **$BV_{DSS}$  (Minimum) : 600 V**
- **$R_{DS(ON)}$  (Maximum) : 1 ohm**
- **$I_D$  : 7.0 A**
- **$Q_g$  (Typical) : 30 nc**
- **$P_D$  (@TC=25 °C) : 142 W**

## General Description

This power MOSFET is produced in CHMC with advanced VDMOS process, planar stripe. This technology enable power MOSFET to have better characteristics, such as fast switching time, low on resistance, low gate charge and especially excellent avalanche characteristics. This power MOSFET is usually used at high efficient DC to DC converter block and switch mode power supply.

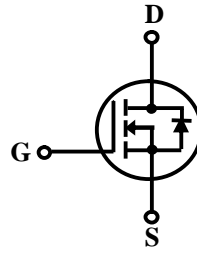
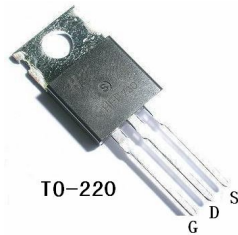

## Absolute Maximum Ratings

Symbol	Parameter	Value	Units
$V_{DSS}$	Drain to Source Voltage	600	V
$I_D$	Continuous Drain Current (@Tc=25°C)	7	A
	Continuous Drain Current (@Tc=100°C)	4.7	A
$I_{DM}$	Drain Current Pulsed (Note 1)	28	A
$V_{GS}$	Gate to Source Voltage	±30	V
$E_{AS}$	Single Pulsed Avalanche Energy (Note 2)	530	mJ
$E_{AR}$	Repetitive Avalanche Energy (Note 1)	14.2	mJ
dv/dt	Peak Diode Recovery dv/dt (Note 3)	4.5	V/ns
$P_D$	Total Power Dissipation (@Tc=25°C)	142	W
	Derating Factor above 25°C	1.14	W/°C
$T_{STG}, T_J$	Operating junction temperature & Storage temperature	-55~+150	°C
$T_L$	Maximum Lead Temperature for soldering purpose, 1/8 from Case for 5 seconds.	300	°C

## Thermal Characteristics

Symbol	Parameter	Value			Units
		Min	Typ	Max	
$R_{\theta JC}$	Thermal Resistance, Junction-to-Case	-	-	0.88	°C/W
$R_{\theta CS}$	Thermal Resistance, Case-to-Sink	-	0.5	-	°C/W
$R_{\theta JA}$	Thermal Resistance, Junction-to-Ambient	-	-	62.5	°C/W

## Electrical Characteristics (Tc=25°C unless otherwise noted)

Symbol	Parameter	Test Conditions	Value			Units
			Min	Typ	Max	
<b>Off Characteristics</b>						
BV <sub>DSS</sub>	Drain- Source Breakdown Voltage	V <sub>GS</sub> =0V, I <sub>D</sub> =250uA	600	-	-	V
ΔBV <sub>DSS</sub> /ΔT <sub>J</sub>	Breakdown Voltage Temperature coefficient	I <sub>D</sub> =250uA, referenced to 25°C	-	0.67	-	V/°C
I <sub>DSS</sub>	Drain-Source Leakage Current	V <sub>DS</sub> =600V, V <sub>GS</sub> =0V	-	-	1	uA
		V <sub>DS</sub> =480V, Tc=125°C				
I <sub>GSS</sub>	Gate-Source Leakage Current	V <sub>GS</sub> =30V, V <sub>DS</sub> =0V	-	-	100	nA
	Gate-Source Leakage Reverse	V <sub>GS</sub> =-30V, V <sub>DS</sub> =0V	-	-	-100	nA
<b>On Characteristics</b>						
V <sub>GS(th)</sub>	Gate Threshold Voltage	V <sub>DS</sub> =V <sub>GS</sub> , I <sub>D</sub> =250uA	3.0	-	5.0	V
R <sub>DS(ON)</sub>	Static Drain-Source On-state Resistance	V <sub>GS</sub> =10V, I <sub>D</sub> =3.5A	-	0.85	1	ohm
<b>Dynamic Characteristics</b>						
C <sub>iss</sub>	Input Capacitance	V <sub>GS</sub> =0V, V <sub>DS</sub> =25V, f=1MHz	-	1200	1500	pF
C <sub>oss</sub>	Output Capacitance		-	150	190	
C <sub>rss</sub>	Reverse Transfer Capacitance		-	18	25	
<b>Switching Characteristics</b>						
t <sub>d(on)</sub>	Turn-on Delay Time	V <sub>DD</sub> =300V, I <sub>D</sub> =7.0A (Note4,5)	-	35	70	ns
t <sub>r</sub>	Rise Time		-	79	130	
t <sub>d(off)</sub>	Turn-off Delay Time		-	80	240	
t <sub>f</sub>	Fall Time		-	52	100	
Q <sub>g</sub>	Total Gate Charge	V <sub>DS</sub> =480V, V <sub>GS</sub> =10V, I <sub>D</sub> =7.0A (Note4,5)	-	30	-	nC
Q <sub>gs</sub>	Gate-Source Charge		-	6.5	-	
Q <sub>gd</sub>	Gate-Drain Charge (Miller Charge)		-	13	-	

## Source-Drain Diode Ratings and Characteristics

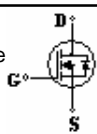
Symbol	Parameter	Test Conditions	Min.	Typ.	Max.	Unit.
I <sub>S</sub>	Continuous Source Current	Integral Reverse p-n Junction Diode in the MOSFET 	-	-	7	A
I <sub>SM</sub>	Pulsed Source Current		-	-	28	
V <sub>SD</sub>	Diode Forward Voltage	I <sub>S</sub> =7.0A, V <sub>GS</sub> =0V	-	-	1.4	V
t <sub>rr</sub>	Reverse Recovery Time	I <sub>S</sub> =7.0A, V <sub>GS</sub> =0V, di/dt=100A/us	-	320	-	ns
Q <sub>rr</sub>	Reverse Recovery Charge		-	2.4	-	uc

### ※NOTES

1. Repeativity rating: pulse width limited by junction temperature
2. L=19.5mH, I<sub>AS</sub>=7.0A, V<sub>DD</sub>=50V, R<sub>G</sub>=0ohm, Starting T<sub>J</sub>=25°C
3. I<sub>SD</sub>≤7.0A, di/dt≤100A/us, V<sub>DD</sub>≤BV<sub>DSS</sub>, Starting T<sub>J</sub>=25°C
4. Pulse Test: Pulse Width≤300us, Duty Cycle≤2%
5. Essentially independent of operating temperature.

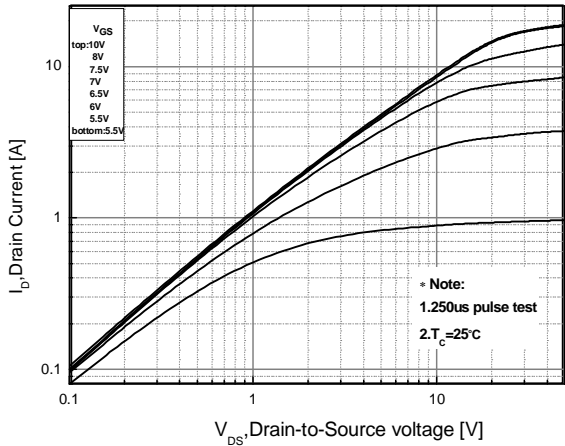

**Fig 1. On-State Characteristics**

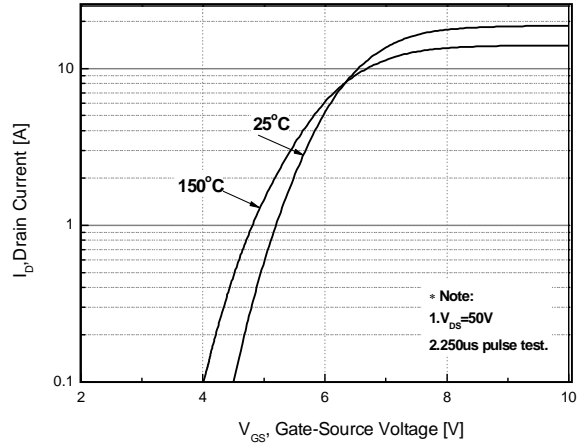

**Fig 2. Transfer Characteristics**

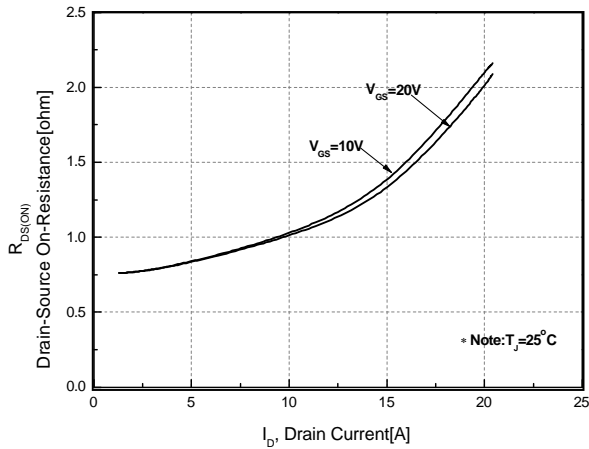

**Fig 3. On Resistance Variation vs. Drain Current and Gate Voltage**

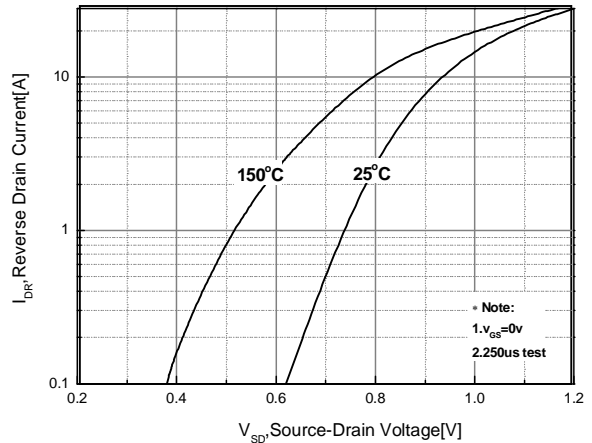

**Fig 4. On State Current vs. Allowable Case Temperature**

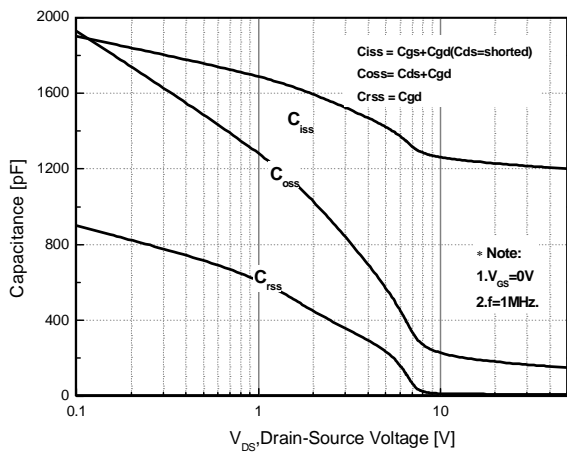

**Fig 5. Capacitance Characteristics (Non-Repetitive)**

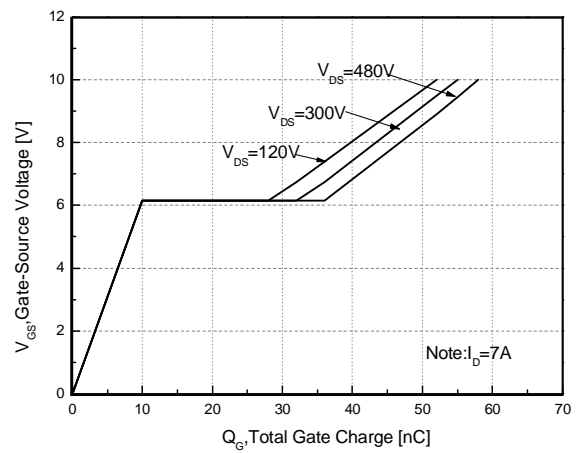

**Fig 6. Gate Charge Characteristics**

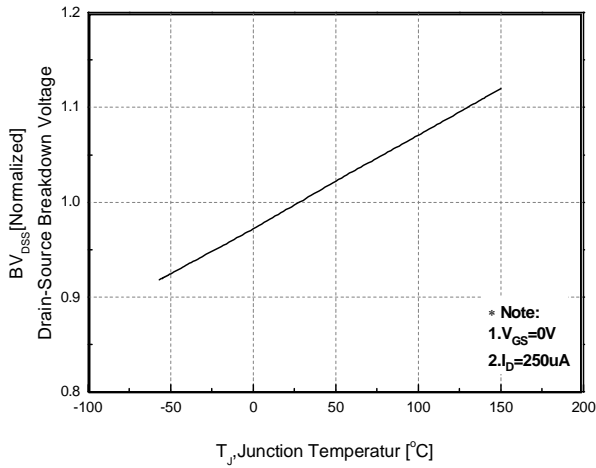

**Fig 7. Breakdown Voltage Variation vs. Junction Temperature**

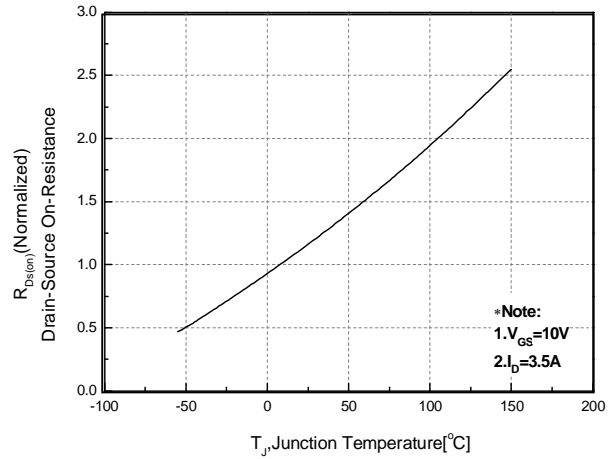

**Fig 8. On-Resistance Variation vs. Junction Temperature**

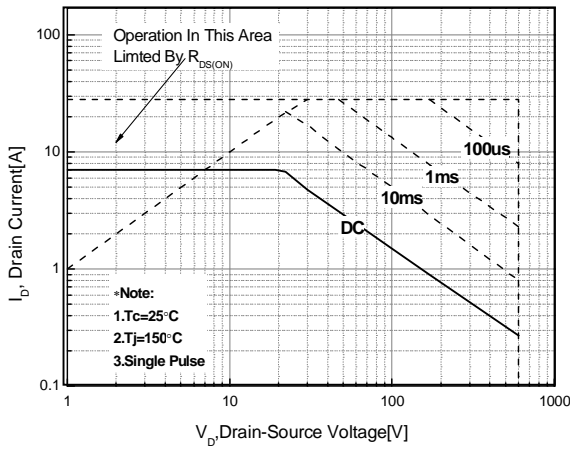

**Fig9. Maximum Safe Operating**

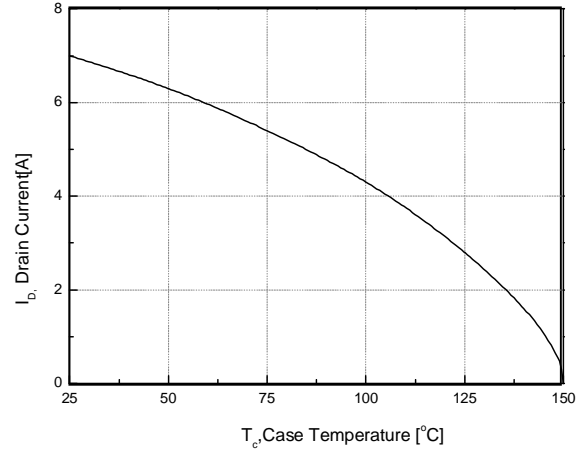

**Fig 10. Maximum Drain Current Vs. Case Temperature**

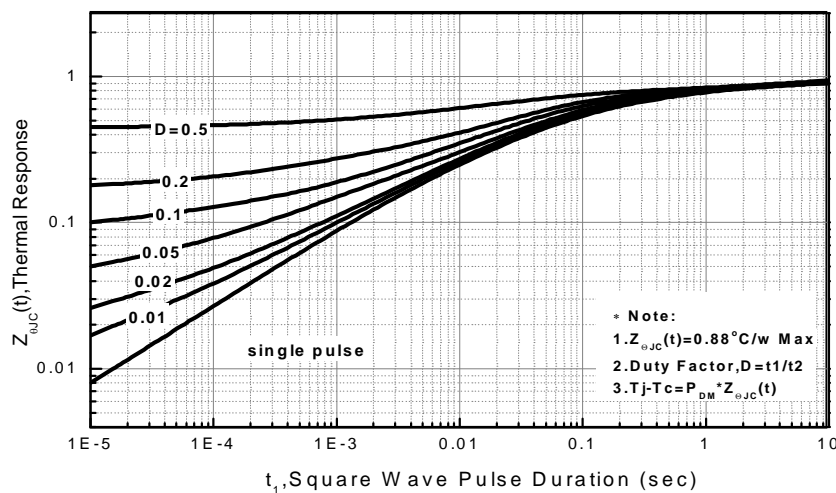

**Fig 11. Transient Thermal Response Curve**

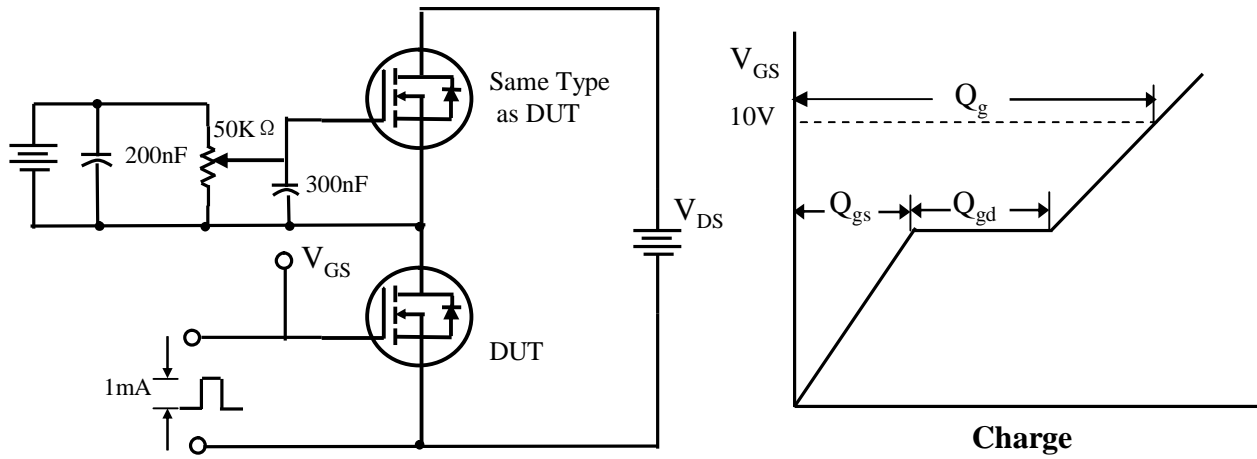

Fig 12. Gate Charge test Circuit & Waveforms

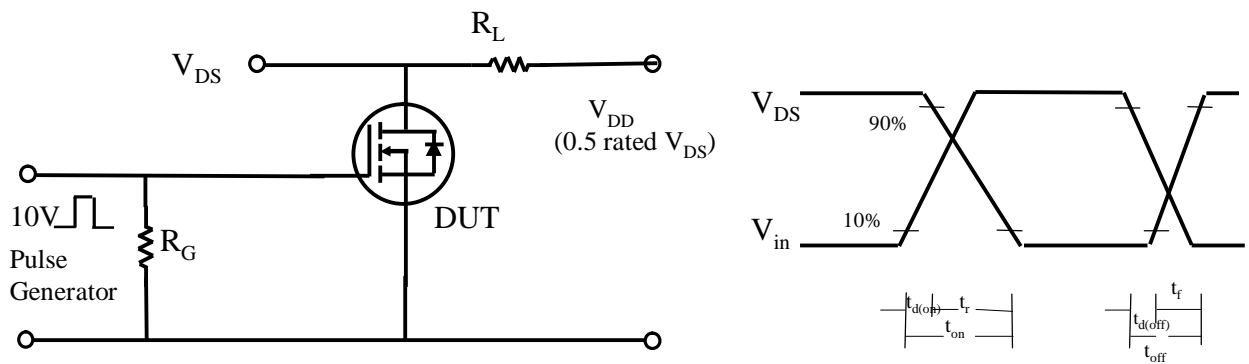

Fig 13. Switching test Circuit & Waveforms

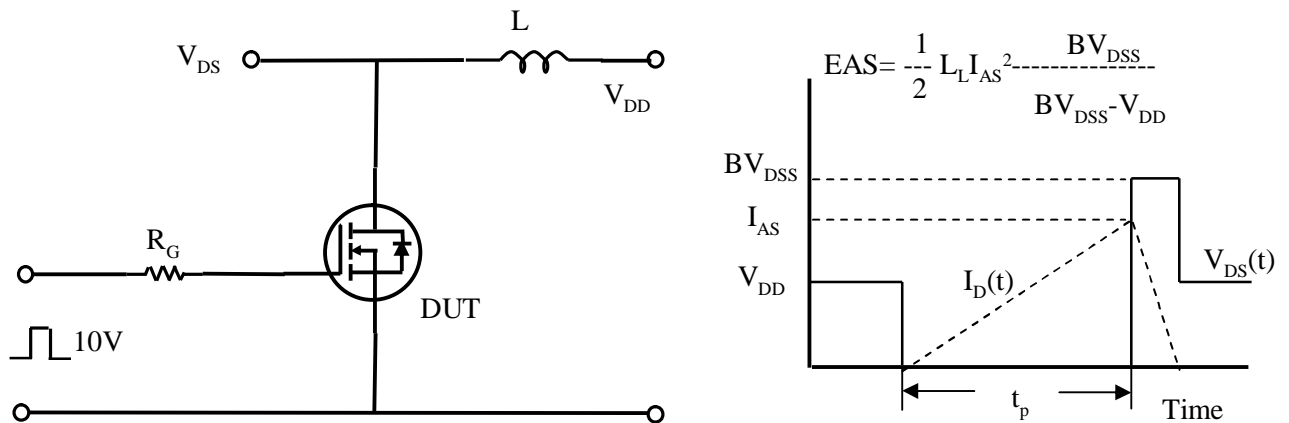

Fig 14. Unclamped Inductive Switching test Circuit & Waveforms